

TEMPERATURE TO CURRENT CONVERTERS STI AND STID (4–20 mA)



DESCRIPTION AND APPLICATION

STI and STID converters are intended for converting the signal of Ni 1000/6180, Pt 100/3850 or Pt 1000/3850 resistance-type temperature sensing elements to the unified signal 4–20 mA. These converters can be utilised in any control system compatible with 4–20 mA current output. Standard measuring ranges of the converter are listed in the specifications table. Operating temperature range is -30 to 80 °C. These limits must not be exceeded even for a short time.

The sensors are designed to be operated in a chemically non-aggressive environment. Two variants exist regarding to the design of the converter case:

1. STI Pt and STI Ni converters: the plastic case is made of POLYAMID material, and is identical to, for example, the connection head of S 120 sensors. It is provided with a wall bracket or with a clip for attaching to a DIN console. The terminal board casing meets the IP 65 ingress protection requirements according to the EN 60 529 standard.

2. STID Pt and STID Ni converters: the plastic box is made of NORYL SE1 material and is provided by a self-extinguishing retarder. It is intended for installation directly to a switchboard on a DIN console. The terminal board casing meets the IP 20 ingress protection requirements according to the EN 60 529 standard.



DECLARATION, CERTIFICATES, CALIBRATION

EC Declaration of Conformity – in accordance with Act No. 22/1997 Coll. as amended for converters with an output of 4 to 20 mA.

Calibration – we perform standard calibration of resistance temperature sensors in accordance with EN ISO/IEC 17025 standard in the temperature range of the stated type of sensor.

SPECIFICATIONS

Converter type	STI Ni STID Ni	STI Pt 100 STID Pt 100	STI Pt 1000 STID Pt 1000
Input signal	Ni 1000/6180	Pt 100/3850	Pt 1000/3850
Output signal	4 to 20 mA		
Power supply (Vcc)	11 to 30 V DC for STI; 10 to 30 V DC for STID (Recommended value 24 V DC)		
Maximum voltage ripple Vcc	0.5 %		
Standard measuring ranges	-30 to 60 °C	-30 to 60 °C	-30 to 60 °C
	0 to 35 °C	0 to 35 °C	0 to 35 °C
	0 to 100 °C	0 to 100 °C	0 to 100 °C
	0 to 150 °C	0 to 150 °C	0 to 150 °C
	0 to 250 °C	0 to 200 °C	0 to 200 °C
		0 to 400 °C	0 to 400 °C
Terminal board ingress protection	IP 65 (for STI), IP 20 (for STID) according to EN 60 529		
Ambient temperature	-30 to 80 °C		
Measurement error	< 0.6 % of the measuring range, minimum 0.5 °C		
Load resistance	50(Vcc - 10) Ω for STI; 50(Vcc - 9) Ω for STID		
Output current for sensing element break	> 24 mA		
Output current for sensing element short	< 3.5 mA		
Sensor connection	according to the wiring diagram		
Recommended wire cross section	STI: 0.35 to 1.5 mm ² STID: 0.35 to 4 mm ²		
Material of the case	STI: POLYAMID STID: NORYL SE1		
Working conditions	ambient temperature: -30 to 80 °C		
	relative humidity: max. 85 % (at the ambient temperature 25 °C)		
	atmospheric pressure: 87 to 107 kPa		
Mass	0.15 kg		

DIMENSIONAL DRAFT

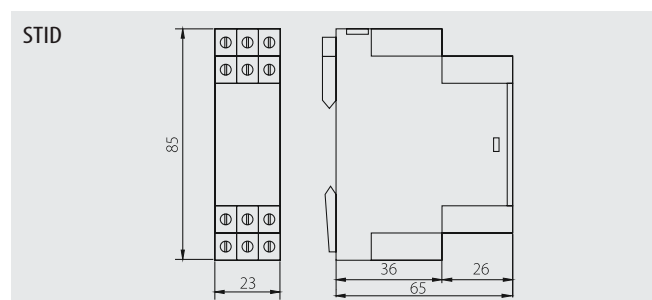
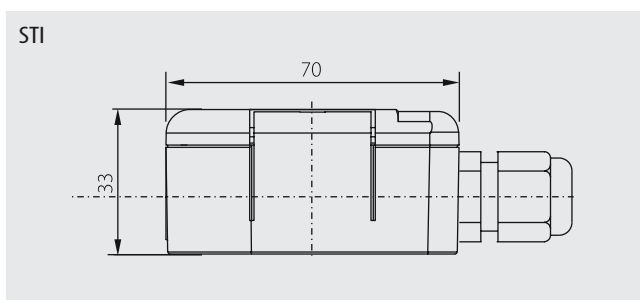

TEMPERATURE TO CURRENT CONVERTERS STI AND STID (4–20 mA)

WIRING DIAGRAM

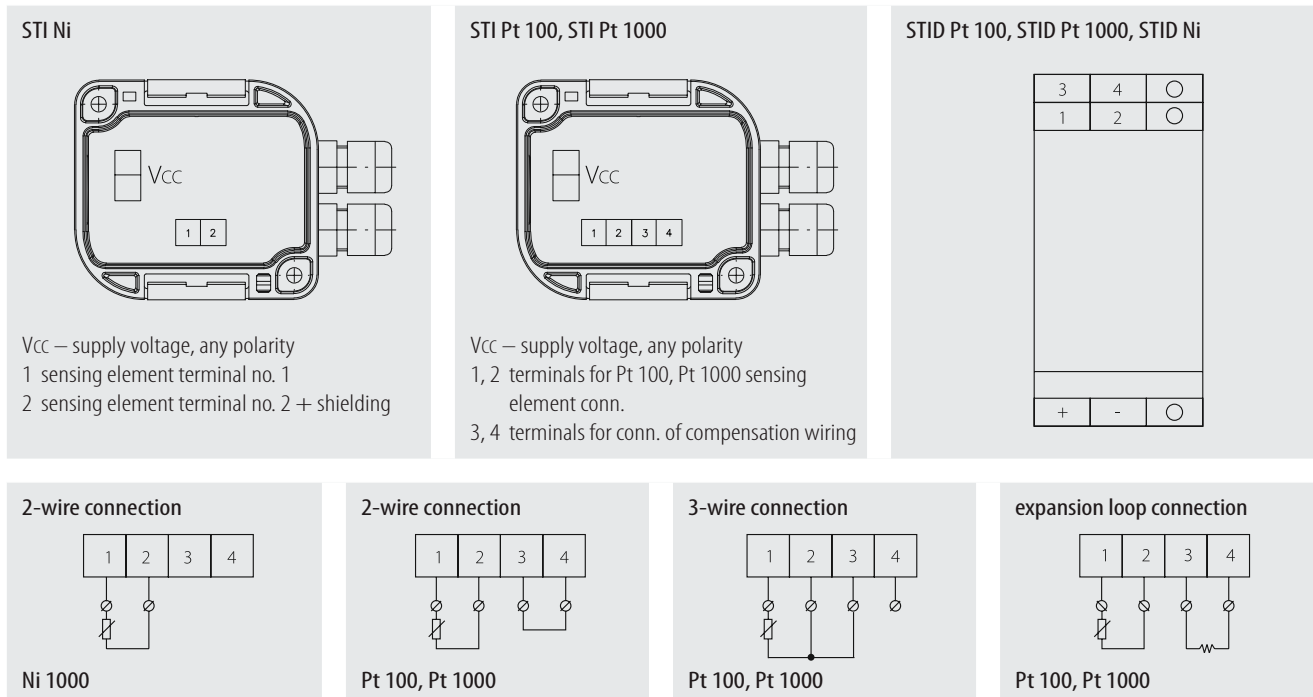

SENSOR INSTALLATION AND SERVICING

Prior to connecting the lead-in cables of the resistance-type sensing element and supply voltage it is necessary to attach the converter to a wall or a DIN console and, if dealing with the STI Pt or STI Ni variant, to unscrew the connection head lid. The lead-in cables of a resistance-type sensing element are then connected to the corresponding terminals according to the wiring diagram. Recommended wire cross-section is determined by terminal board type and can be found in the specifications table. In case the lead-in cable is laid in the vicinity of high voltage conductors or those supplying equipment creating disturbing electromagnetic field (e.g. inductive load equipment), a shielded cable should be used. To insure the ingress protection value of IP 65 of STI Pt or STI Ni variants the grommet has to be tightened and the lid has to be screwed on after connecting the lead-in cable. After installing and connecting the sensor to the appropriate evaluating electrical equipment, it is ready to use. The sensor does not require any special servicing or maintenance. The device can be operated in any working position, but the grommet must not be directed upwards.